

# Precision Microfluidic Control

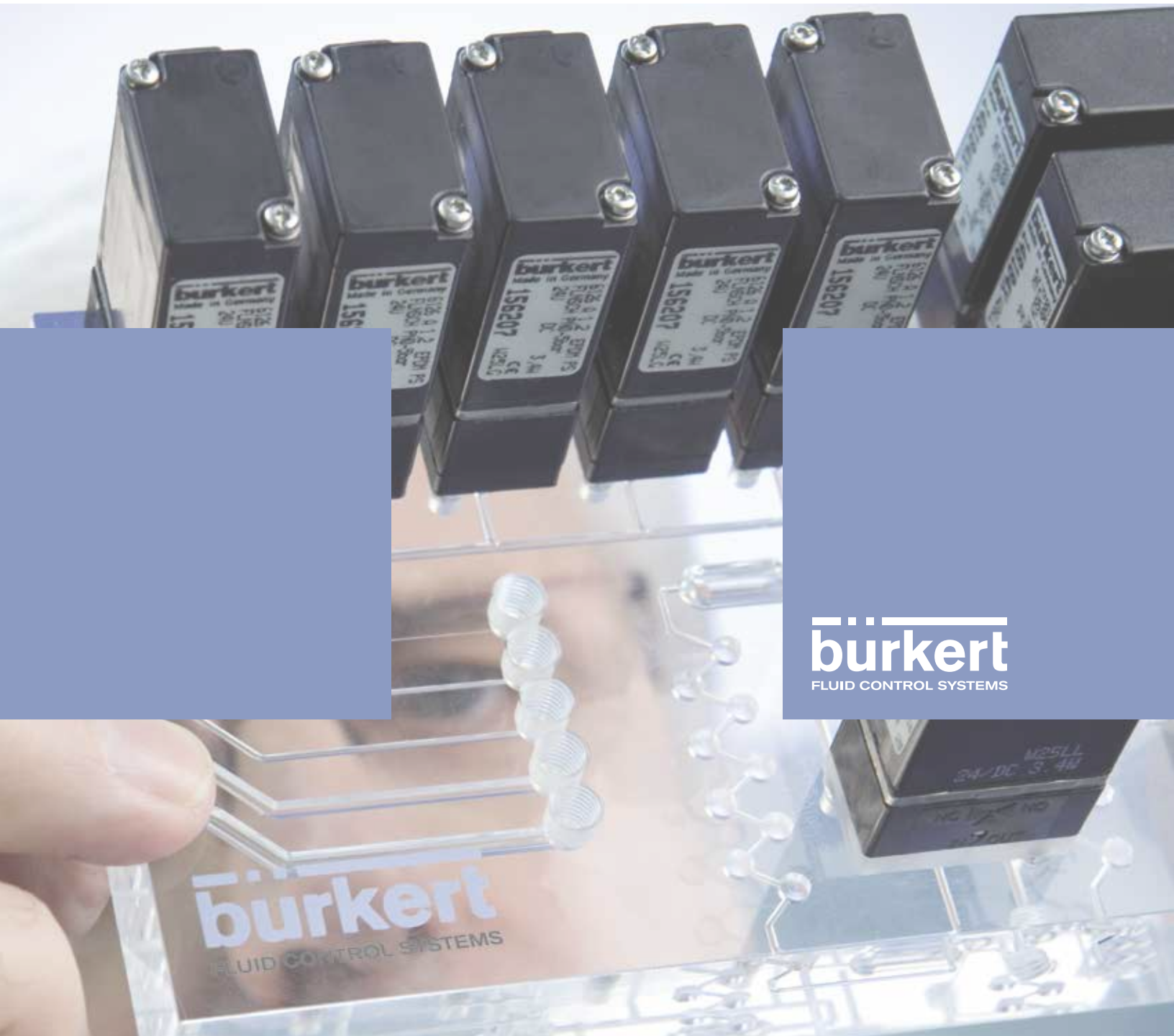

**burkert**  
FLUID CONTROL SYSTEMS

# Our Micro Fluidic Valve Innovations

6712



plunger type with diaphragm

6724



large plunger type with diaphragm

6164



Cartridge solenoid valve

<b>Robust</b>	✓	✓	✓
<b>Compact</b>	✓	✓	✓
<b>Low dead volume</b>	✓	✓	-
<b>100% duty cycle</b>	✓	✓	✓
<b>Low-power consumption</b>	✓	✓	✓
<b>Medical-grade</b>	✓	✓	✓
<b>Flange Mount</b>	✓	✓	-
<b>Cartridge Mount</b>	-	-	✓
<b>Orifice</b>	<b>0.8</b>	<b>0.8 - 1.2</b>	<b>0.5 - 1.2</b>
<b>2/2</b>	✓	✓	-
<b>3/2</b>	-	✓	✓

# Compact, Robust and Precise!



## **Type 6650 – Flipper valve**

With a width of just 4.5 mm, Type 6650 sets new industry standards. Along with its compact design, the 6650's extremely fast and high-precision switching makes it ideal for dosing tasks in the microliter range (3  $\mu$ l with CV of < 3 %). Further advantages of the valve are its capability to handle pressures up to 7 bar (101 psi). With a service life of up to 200 million cycles at 4.5 bar, it gives you more reliability.



## **Type 6712 – WhisperValve – plunger type with diaphragm**

With its compact size (7mm width and 26 mm height), the media separated diaphragm valve Type 6712, WhisperValve, is ideal for integration in small, portable machines or on pipetting arms. Minimal switching noise of <36 dB, makes this valve ideal for laboratory environments and point-of-care applications. Fast switching guarantees precision dosing in any application. The low internal volume of only 5 $\mu$ l and excellent flushability, eliminates chance of cross contamination and guarantees reliable results.



## **Type 6164 – Cartridge solenoid valve**

For non-aggressive media, the Type 6164 features a compact design with 11 mm width per station, orifices from 0.5 mm (9 bar/130 psi) to 1.2 mm (1.5 bar/21.7 psi), high durability and reliability, low power consumption in a low cost spring plunger style valve package.



## **Type 6144 – Flipper valve**

The medium separated Type 6144 has been designed for general purpose use and is especially suitable in pneumatic applications. The valve boasts a particularly long service life of more than 500 million cycles for greater reliability. It can be applied in many different applications thanks to its ability to handle pressures of up to 10 bar (145 psi). It is also available in a latching/impulse version.



## **Type 0331 – Pivoted armature valve**

Type 0331 is especially suitable for the control of aggressive or waste media, which require media isolation from the actuator. Depending on the orifice, the valve is suitable for pressures up to 16 bar (232 psi), and an orifice of up to 5 mm allows for high flow rates.

# Compact, Robust and Precise!



## **Type 6724 – Rocker WhisperValve**

Type 6724 is the larger version of the WhisperValve Type 6712 (9 mm width, 43 mm height, and 1.2 mm orifice). A membrane separates the fluid chamber from the actuator for use in applications involving aggressive media. With the nearly silent switching, it is perfect for the laboratory and medical applications providing a quiet environment at the patient's side. The low internal volume of 29  $\mu$ l, excellent flushability and precision dosing guarantee reliable testing results.



## **Type 0127 – Rocker valve**

The pioneer of media-separated valves sets the standard in the field of laboratory, medical and analytical devices since 1993. Minimal internal volume and excellent flushability combine to minimize waste of process media and risk of contamination. The 0127 is able to cover a wide range of applications due to its wide spectrum of material and process connection options.



## **Type 6624 – TwinPower Rocker valve**

The new TwinPower actuator enables a radical reduction in size and footprint, for more flexibility in positioning while saving space for your innovations, without compromise in performance. With only 10 mm pitch, our media-separated rocker valve comes along with 1.6 mm orifice and 2 bar (29 psi) pressure resistance – the same performance data as the traditional, larger 16 mm rocker valve.



## **Type 6626 – TwinPower Rocker valve**

The Type 6626 is the larger counterpart of Type 6624, also incorporating TwinPower coil technology. With pressures ranging from vacuum to 2 bar (29 psi) and an orifice of 3 mm, TwinPower allows for a valve with only 16 mm in width, increasing the size-to-performance ratio. An integrated LED enables clearly visible status monitoring of the valve.



## **Type 6628 – Rocker valve**

The 22 mm valve complements the TwinPower family by using the same fluidic design as the proven and reliable Type 0127. Time proven rocker technology is characterized through its reliable sealing of the valve seat with full back pressure tightness. Low internal volume and excellent flushability reduce the risk of costly media waste and process contamination. A comprehensive list of material, sealing and mounting options ensure coverage of a wide range of applications.

# Compact, Robust and Precise!



## Type 7604 – Microfluidic pump

Our self-priming diaphragm pump is ideal for continuous low flow liquid applications and provides a plug-and-play solution for simple start-ups. This micro pump is suitable for applications with aggressive process media due to media isolating high chemical resistance elastomer membranes. The mounting pitch of 11 mm allows for an extremely compact design and ease of mounting, with standard bodies designed for surface mount (manifold) or tube connections. The low power consumption of just 1.5 watt means the pump can be easily incorporated into battery-powered mobile devices. The flow rate can be adjusted by varying the frequency input to fit your specific system requirements.



## Type 7615 – Bidirectional Microfluidic pump

The Micro Dosing Unit 7615 consists of a diaphragm pump and active inlet and outlet valves. The components are assembled on a manifold in order to keep the internal volume to a minimum. The delivered volume can be adjusted via the cycle rate for more flexibility. Thanks to its high reproducibility ( $< \pm 2\%$ ), the unit is ideal for precise dosing of the smallest quantities of liquids and guarantees high quality test results. PEEK and FFKM are the only materials that come into contact with the medium. This facilitates the use of aggressive media. The Micro Dosing Unit can be easily connected via a 4-pole plug. It has an integrated electronics for an immediate use.



## Pneumatic dosing system

With the combination of a compact fluid chamber and an integrated control unit for pressure and vacuum, Bürkert designed a truly unique dosing system customizable to your application. The compact and modular nature of this system allow for combination of multiple units within a small footprint. Chemical resistant media isolation elastomer accommodate aggressive processes while high flexibility in dosing volume and velocity allow for a high degree of customization.

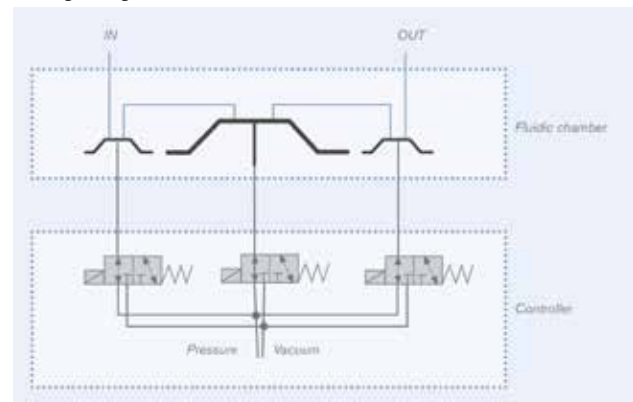

# Systemhaus Capabilities



Burkert's team is well equipped to fully understand next generation requirements for innovative designs, lean manufacturing, packaging, and quality.

- design team engineering
- project engineering
- Manufacturing and quality engineering
- assembly and automated testing
- clean room assembly and testing
- machining, molding, enclosure assembly
- in house quality testing services

Solution provider services

- engineering design, technical expertise, sales and service
- Kanban-JIT inventory services East and West Coast
- single source for pneumatic and liquid valves, sensors and automation solutions
- value added/pre-tested assemblies: bagged, tagged, kitted.
- single part number system set ordering
- custom OEM / customer specific part number creation

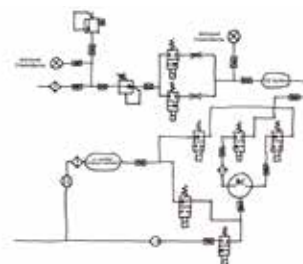
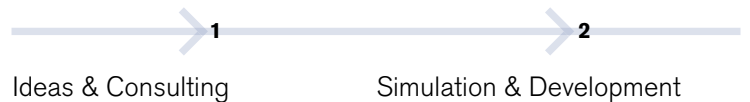

# Systemhaus Capabilities

Our Systemhaus capabilities and extensive industry experience enables our team to specialize in a wide variety of customized fluidic solutions from simple valve modifications and machined and injection molded plastic parts to complex fluidic assemblies including valves, pumps, sensors, software, and advanced communication protocols.

Your idea ignites a team of experienced engineering consultants, a foundation of the most robust and innovative fluid handling products, in house capabilities designed especially for prototyping, manufacturing and testing; all dedicated to providing Life Science instruments, service, and support for the life of your custom system solution.

Our goals are your goals. Innovation, reliability, feasibility, serviceability, cost, etc.

We want to be your system integration partner of choice for your next generation fluid control system, from concept to reality.

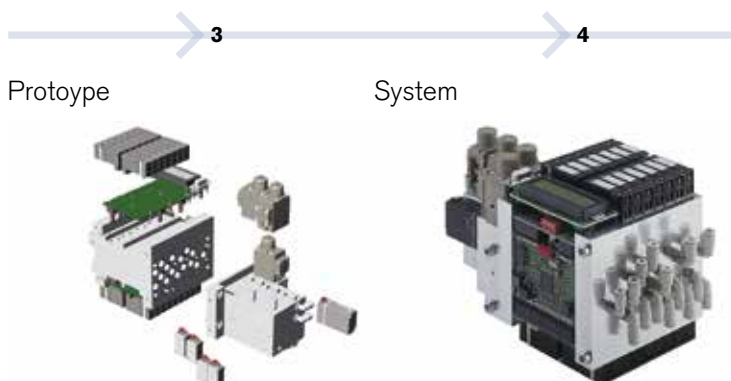

# Flipper Valves

The core component in flipper valves is a metal lid vulcanized with elastomer. This pivoting "flipper" is housed in the fluid chamber and alternately closes one of the two valve seats.

As in valves with diaphragms, flipper valves provide a complete separation of medium and actuator. However, the switching action of the flipper creates no pump effect. In addition, the flipper valve technology allows for especially short and reproducible response times and an extended service life due to the lack of diaphragm flexing. This makes this technology particularly

suitable for precise dosing applications.

Since the medium does not act on large areas of a diaphragm, flipper valves remain tight even at back pressures above the nominal pressure.

Characteristics:

- short and reproducible response times
- no pulsation
- low power consumption
- enclosed fluid chamber

# Rocker Valves

The valve seats in rocker valves are in one plane and opened and closed by a switching rocker. Due to the extremely small amount of moving mass involved, the distinguishing feature of rocker valves is their particularly long service life.

Alongside the non-media-separated valves for pneumatic applications, the principle behind rocker valves also allows for the reliable separation of medium and actuator by way of a diaphragm. In contrast to plunger type valves with a diaphragm, the construction principle of rocker valves provides a secure

seal of the valve seats even if a high back pressure is applied. Due to the lack of gaps in the inner contour and the very good cleanability of the fluid chamber, the media-separated rocker valves are particularly well suited for use with biological media.

Characteristics:

- excellent cleanability
- minimal internal volume
- high back pressure tightness
- media separated from actuator

# Plunger Valves

The main components of this valve type are a coil, a closing spring, a valve body cover and the valve body with the seat. Without current the path to the outlet is blocked (normally closed), since the closing spring presses the plunger onto the valve seat. If current flows through the coil, the latter generates a starting force, which pulls the plunger and the seal against the spring force and draws the medium upward. The channel is opened for the medium.

With a media separating membrane, the valves are used

for the control of gases and fluids in analytical applications.

They are ideal for switching aggressive and high purity media, since the separating diaphragm ensures a hermetically sealed coil and only high-quality plastics are used as the sealing and body material.

Characteristics:

- Long service life
- High pressure and temperature ranges
- Increased switching cycles



power-off position

powered position

3/2-way valve flipper technology

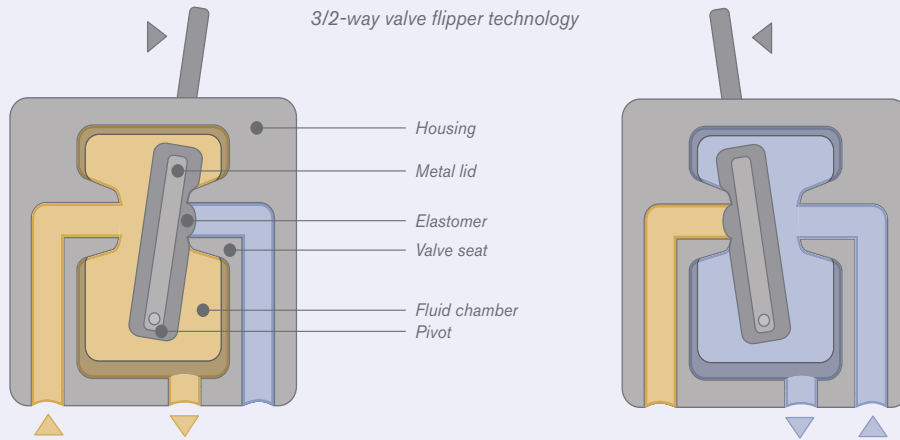

power-off position

powered position

3/2-way valve rocker technology

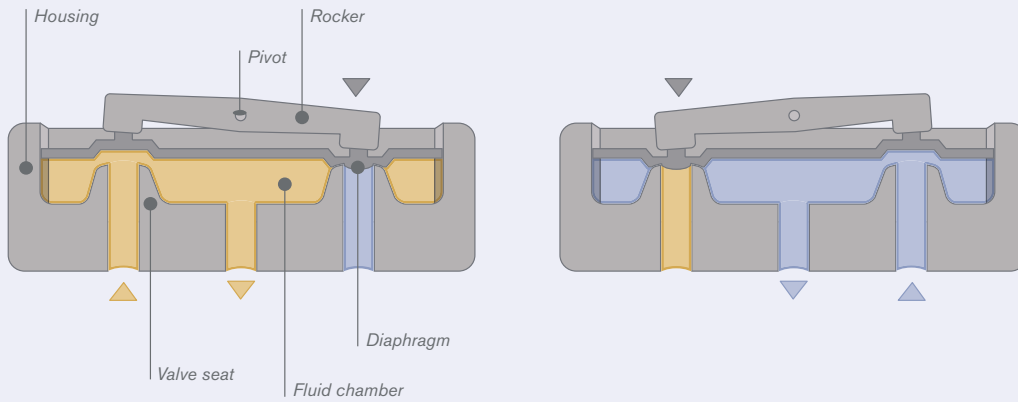

power-off position

powered position

2/2-way valve plunger technology

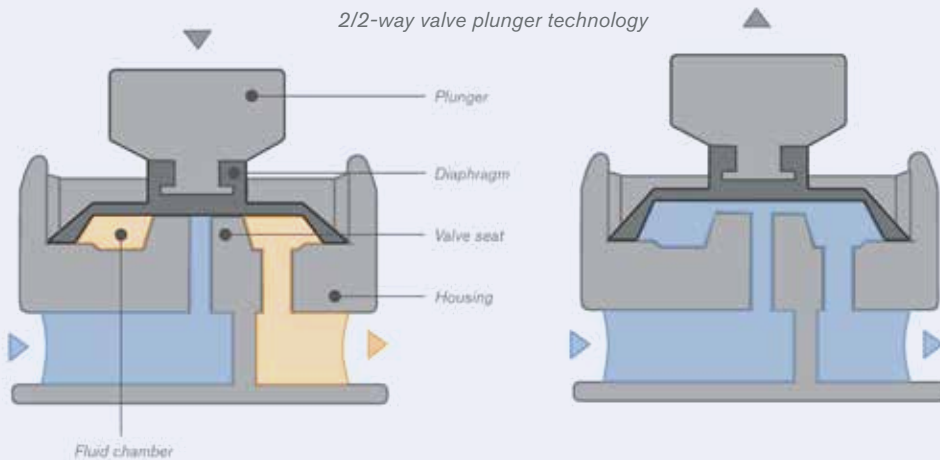

# Customized System Solutions

Customer specific design, manufacture, assembly, test, ordering, packaging, stocking and shipping.

Specializing in -

- consulting, design, and fluid system integration
- complete fluidic systems, sub-assemblies to simple value-added products
- manifolds: machined, molded, bonded, sandwich...(from all materials plastic and metal)
- sheet metal bracket assemblies and enclosures
- machined and molded parts

Integration including -

- valves, pumps, and sensors
- fittings, needles and tubing
- electronics and connectors

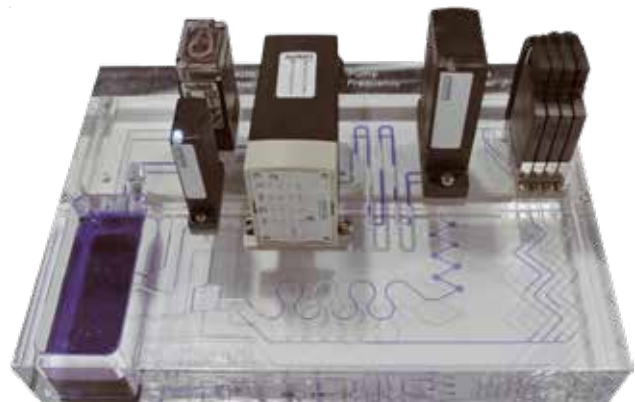

Country	Address	Email	Web
<b>Argentina</b>	Buenos Aires	contacto.argentina@burkert.com	<a href="https://www.burkert.com.ar/es">https://www.burkert.com.ar/es</a>
<b>Australia</b>	Baulkham Hills	sales.au@burkert.com	<a href="https://www.burkert.com.au/en">https://www.burkert.com.au/en</a>
<b>Austria</b>	Wien	info@buerkert.at	<a href="https://www.buerkert.at/de">https://www.buerkert.at/de</a>
<b>Beijing</b>	Beijing	info.chn@burkert.com	<a href="https://www.burkert.com.cn">https://www.burkert.com.cn</a>
<b>Belgium</b>	Wijnegem Zone 1 "De Hoek"	sales.be@burkert.com	<a href="https://www.burkert.nl/nl">https://www.burkert.nl/nl</a>
<b>Brazil</b>	São Paulo	burkert@burkert.br	<a href="https://www.burkert.com.ar/es">https://www.burkert.com.ar/es</a>
<b>Canada</b>	Burlington, Ontario	sales.ca@burkert.com	<a href="https://www.burkert.ca">https://www.burkert.ca</a>
<b>Chengdu</b>	Chengdu	info.chn@burkert.com	<a href="https://www.burkert.com.cn">https://www.burkert.com.cn</a>
<b>China</b>	Shanghai	info.chn@burkert.com	<a href="https://www.burkert.com.cn">https://www.burkert.com.cn</a>
<b>Czech Republic</b>	Krenova 35	obchod@burkert.cz	<a href="https://www.burkert.cz/cz">https://www.burkert.cz/cz</a>
<b>Denmark</b>	Herlev	info.dk@burkert.com	<a href="https://www.burkert.dk/da">https://www.burkert.dk/da</a>
<b>Estonia</b>	Tallinn	info@burkert.ee	<a href="https://www.burkert.com">https://www.burkert.com</a>
<b>Finland</b>	Helsinki	sales.fi@burkert.com	<a href="https://www.burkert.fi">https://www.burkert.fi</a>
<b>France</b>	Triembach au Val	burkert.france@burkert.com	<a href="https://www.burkert.fr">https://www.burkert.fr</a>
<b>Germany</b>	Ingelfingen	info@buerkert.de	<a href="https://www.buerkert.de">https://www.buerkert.de</a>
<b>Guangzhou</b>	Guangzhou	info.chn@burkert.com	<a href="https://www.burkert.com.cn">https://www.burkert.com.cn</a>
<b>Hong Kong</b>	Kwai Chung	info.hkg@burkert.com	<a href="https://www.burkert.com.hk/cn">https://www.burkert.com.hk/cn</a>
<b>India</b>	Chennai	sales.in@burkert.com	<a href="https://www.burkert.in/en">https://www.burkert.in/en</a>
<b>Italy</b>	Cassina De' Pecchi	info@buerkert.it	<a href="https://www.burkert.it">https://www.burkert.it</a>
<b>Japan</b>	Tokyo	info.jpn@burkert.com	<a href="https://www.burkert.jp">https://www.burkert.jp</a>
<b>Korea</b>	Seoul	info.kor@burkert.com	<a href="https://www.burkert.com">https://www.burkert.com</a>
<b>Malaysia</b>	Penang	info.sin@burkert.com	<a href="https://www.burkert.com">https://www.burkert.com</a>
<b>New Zealand</b>	Auckland	sales.nz@burkert.com	<a href="https://www.burkert.co.nz/en">https://www.burkert.co.nz/en</a>
<b>Netherlands</b>	Utrecht	info@burkert.nl	<a href="https://www.burkert.nl">https://www.burkert.nl</a>
<b>Norway</b>	Skjetten	info@burkert.no	<a href="https://www.burkert.no">https://www.burkert.no</a>
<b>Osaka</b>	Osaka	info.jpn@burkert.com	<a href="https://www.burkert.jp">https://www.burkert.jp</a>
<b>Phillippines</b>	Manila	info.rp@burkert.com	<a href="https://www.burkert.com">https://www.burkert.com</a>
<b>Poland</b>	Warszawa	buerkert@buerkert.pl	<a href="https://www.buerkert.pl">https://www.buerkert.pl</a>
<b>Portugal</b>	Alverca	portugal@burkert.com	<a href="https://www.burkert.com">https://www.burkert.com</a>
<b>Queensland</b>	Albion Queensland	sales.au@burkert.com	<a href="https://www.burkert.com.au/en">https://www.burkert.com.au/en</a>
<b>Singapore</b>	Singapore	info.sin@burkert.com	<a href="https://www.burkert.sg/en">https://www.burkert.sg/en</a>
<b>South Africa</b>	Meadowdale, Germiston	sales.za@burkert.com	<a href="https://www.burkert.co.za/en">https://www.burkert.co.za/en</a>
<b>Spain</b>	Barcelona	spain@burkert.com	<a href="https://www.burkert.es">https://www.burkert.es</a>
<b>Suzhou</b>	Suzhou	info.chn@burkert.com	<a href="https://www.burkert.com.cn">https://www.burkert.com.cn</a>
<b>Sweden</b>	Malmö	info.se@burkert.com	<a href="https://www.burkert.se/sv">https://www.burkert.se/sv</a>
<b>Switzerland</b>	Hünenberg	info.ch@buerkert.com	<a href="https://www.buerkert.ch/fr">https://www.buerkert.ch/fr</a> <a href="https://www.buerkert.ch/de">https://www.buerkert.ch/de</a>
<b>Taiwan</b>	Taipei	info.rc@burkert.com	<a href="https://www.burkert.com">https://www.burkert.com</a>
<b>Turkey</b>	Yenisehir, Izmir	burkert@superonline.com	<a href="https://www.burkert.com.tr">https://www.burkert.com.tr</a>
<b>United Kingdom</b>	Circencester	sales.uk@burkert.com	<a href="https://www.burkert.co.uk/en">https://www.burkert.co.uk/en</a>
<b>Victoria</b>	Notting Hill Victoria	sales.au@burkert.com	<a href="https://www.burkert.com.au/en">https://www.burkert.com.au/en</a>
<b>Western Australia</b>	Joondalup	sales.au@burkert.com	<a href="https://www.burkert.com.au/en">https://www.burkert.com.au/en</a>
<b>USA</b>	Huntersville, NC	marketing-usa@burkert.com	<a href="https://www.burkert-usa.com/en">https://www.burkert-usa.com/en</a>



**Burkert Fluid Control Systems**

**USA**

US Headquarters  
11425 Mt. Holly-Huntersville Road  
Huntersville, NC 28078

Phone: 1-800-325-1405

Fax: 949-223-3198

[marketing-usa@burkert.com](mailto:marketing-usa@burkert.com)

[www.burkert-usa.com](http://www.burkert-usa.com)

**Canada**

5002 South Service Road  
Burlington, Ontario L7L 5Y7

Phone: 905-632-3033

Fax: 905-632-3833

[sales.ca@burkert.com](mailto:sales.ca@burkert.com)

[www.burkert.ca](http://www.burkert.ca)

