

PRECISEFLEX SAMPLE HANDLER

Affordable, quiet OEM sample handler designed to optimize the cost, safety and performance of your workcell.

The PreciseFlex is a 4-axis sample handler, with servo gripper, that is ideal for benchtop applications where price, ease-of-use, space requirements and safety are critical.

The PF features a powerful, embedded Guidance Vision-Guided Motion Controller. This controller offers timesaving free mode and auto centering teaching aids and excellent capabilities for automatically generating elegant and reliable motion sequences. Its features permit you to program smooth straight line and arbitrarily complex paths by simply moving the sample handler by hand to start and end positions and letting the controller handle the rest. Combined with a simple, yet powerful programming language, kinematics for Cartesian motions and quiet, high performance servo motors, the PF reduces cycle times with the most efficient motions possible.

When visual feedback is of benefit, Precise's vision software integrates seamlessly with the PreciseFlex. A graphical user interface makes camera calibration and programming easy and intuitive.

The controller, harnesses and power supplies are embedded within the mechanism's structure. Combined with its space saving design, the PreciseFlex is able to service many stations in an extremely small workcell. Also, this sample handler includes safety features that disable motor power when a minimal, unexpected force is encountered, thus allowing the PF to operate without safety shields in benchtop applications.

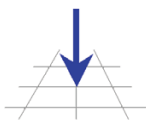

PRECISE
AUTOMATION

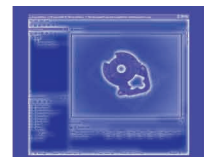
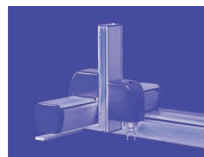

General Specifications	Range & Features
Range of Motion & Resolution	
J1 (Z) Axis	400 mm standard, 750 mm option available
J2 Axis	+/- 90 degrees
J3 Axis	+/- 167 degrees
J4/Theta Axis	+/- 970 degrees
Gripper	Standard servo gripper can grip Life Science plates in both portrait and landscape orientations. Software can control squeeze force (between approximately 0-23N for close force, 0-10N for open force) and open/close speed. Safety features include: (1) protection against dropping plates when sample handler is powered down or e-stop pressed (gripper provides 7-10N of close force when motor power is off) and (2) detection of when a plate is being held by the gripper. Options include gripper fingers and special servo grippers for handling vials and test tubes.
Maximum reach	Standard Reach Version: 576 mm Extended Reach Version: 731 mm
Repeatability	+/- 90 µm overall in x, y & z directions at 18-22 degrees C
Performance and Payload	
Maximum Acceleration	0.2G with 500 gm payload (standard reach, extended reach slightly slower)
Maximum Speed	500 mm/sec with 500 gm payload (standard reach, extended reach slightly slower)
Maximum Payload	1kg including gripper, 0.5kg with typical 0.5kg gripper
Motors	Brushless DC servo motors with absolute encoders on axes J1-J4, no motion during homing.
Interfaces	
General Communications	RS-232 channel, 10/100 Mbps Ethernet port, E-stop input, all available on J1-Axis housing Facilities Panel at the robot base
Digital I/O Channels	One optically isolated input available on J1-Axis housing Facilities Panel. Option available for an additional 12 optically isolated digital inputs and 8 optically isolated digital outputs on J1-Axis housing Facilities Panel. Two digital inputs can be optionally converted to analog inputs. Additional remote I/O available via Precise RIO modules or 3 rd party MODBUS/TCP devices
Operator Interface	Web based operator interface supports local or remote control via browser connected to embedded web server
Programming Interface	Three methods available: DIO MotionBlocks (PLC), embedded Guidance Programming Language (standalone, modeled after Visual Basic.Net), PC control using open source TCP/IP Command Server operated via Ethernet connection (TCP).
Required Power	Input range: 90 to 264 VAC, single phase, 50-60 Hz, 365 watts maximum
Weight	20 kg for 400 mm travel version
Linear Rail Option	
Configurations	Any model of the Sample Handler can be mounted on the Linear Rail with all of the robot's interfacing cables routed internally in the Rail.
Repeatability	+/- 50 µm
Maximum Speed	700 mm/sec
Dimensions	1 M travel version – 1.37 m long x 0.23 m deep x 0.12 m high 1.5 M travel version – 1.87 m long x 0.23 m deep x 0.12 m high 2 M travel version – 2.37 m long x 0.23 m deep x 0.12 m high

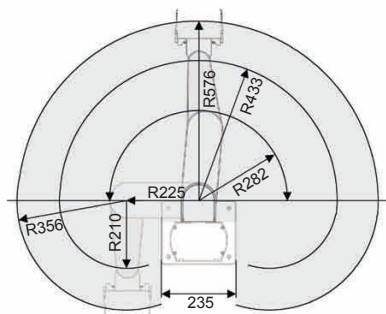

Standard Reach Version

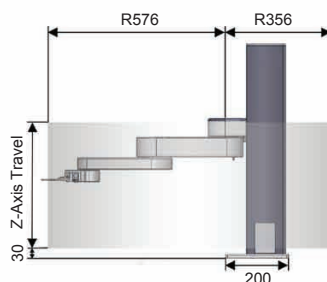

Standard Reach Version



PF Sample Handler on Linear Rail



automate with ease